

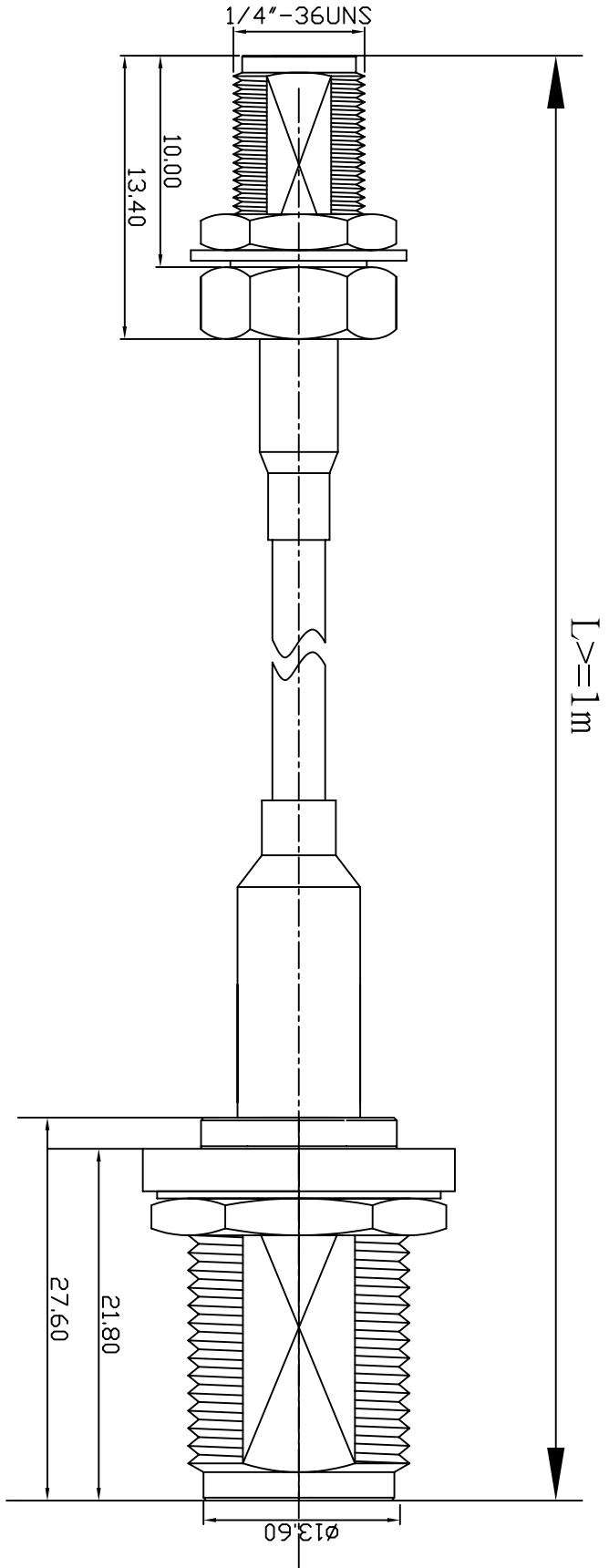

REV	DESCRIPTION	DRAWN	DATE



NO	Description	Qty	Material	Finish
3	N-1159-1-L-TGN	1	BRASS	NICKEL
2	RG174/RG316/LC100	1		
1	SMA-1012-7-L-TGG	1	BRASS	GOLD

1 REMOVE ALL BURRS 2 BREAK ALL CORNERS & EDGES CO.15 MAX. 3 CHAMFER 1ST & LAST THREADS 45°. 4 DIAMETERS ON COMMON CENTERS TO BE CONCENTRIC WITH DIMENSIONS ARE AFTER PLATING.		*MAJOR DIMENSION UNLESS OTHERWISE NOTED TOLERANCES 0.5-6 = ±0.2 6-30 = ±0.4 30-120 = ±0.6 120-315 = ±1.0 ANGLES = ±1°		APPROVED CHECKED DRAWN PEN		 <p>華耀科技有限公司 Hua Yao Technologies co.,Ltd</p>
SCALE	3/1	UNIT	MM	DRAWN DATE	04/09/29	

FILE NDD\DWG\SMA1012-N1159\10127\174\316\100\11591-AL